

承认书

SPECIFICATION FOR APPROVAL

客 户 CUSTOMER 立创商城

品 名 DESCRIPTION 插件工字电感

料 号 ITEM NO. : PK0810-561KB

版 本 REV. : 1.0

日 期 DATE : 2017/8/8

出 图		
DRAWING		
制作	审核	批准
MADE BY	CHECKED BY	APPROVED BY
DATE:	2017年8月8日	

承 认
CUSTOMER APPROVE
请于确认后回签,谢谢!

深圳市顺翔诺电子有限公司

SHENZHEN SHUNXIANGNUO ELECTRONICS CO.,LTD.

深圳地址(ADD): 深圳市龙华观澜大水坑百丽名苑(百丽大厦)6栋7楼

SPECIFICATION FOR APPROVAL

SUSTOMER		CUS.P/N		PAGE NO	2 of 3
SXNP/N	PK0810-561KB	DATE	2017/8/8	REV.	1.0

1.PART NUMBERING SYSTEM

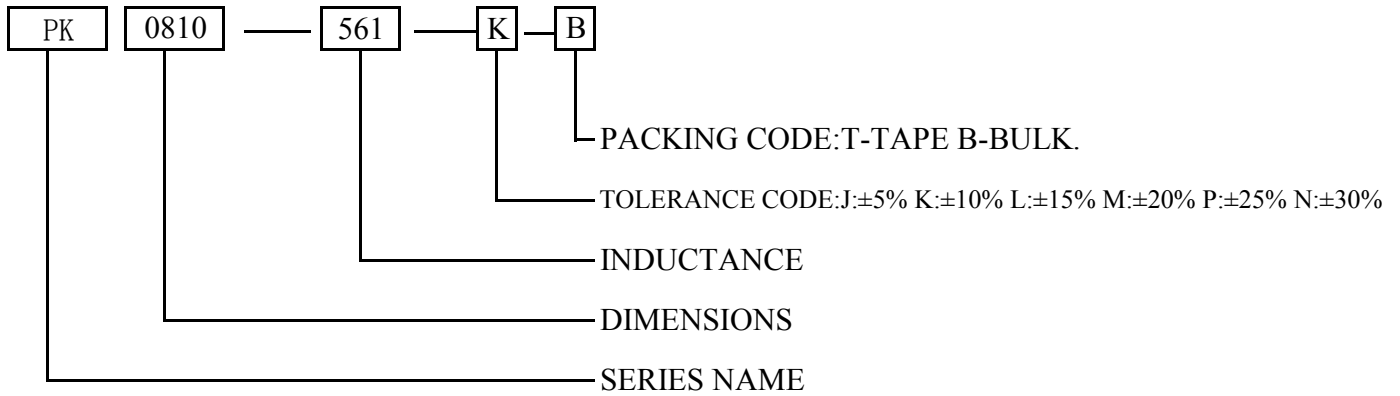

2.EXTERNAL DIMENSIONS:

UNIT:mm

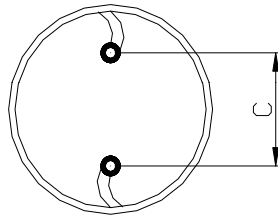
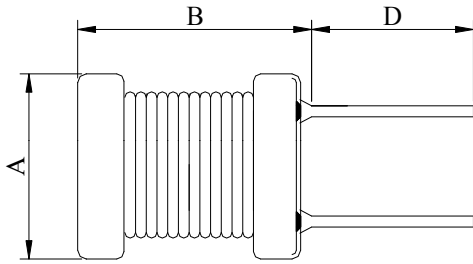

POSITION	DIMENSION
A	9.5Max
B	12.3Max
C	4.0Ref
D	5.0Ref
E	
F	
G	

3.MATERIAL LIST:

ITEM	MATIRIAL	SUPPLIER	NOTE
CORE	DR 2W8*10 B4.0F6.0		
WIRE	∅ 0.25mm(2UEW)/130TS		
SOLDER	Sn99.95		
TUBE	PE黑色) 8*12		
EPOXY			

4.ELECTRICAL CHARACTERISTIC:

L	:1.0UH±30%	1KHz/0.25V	1062 LCZ
RDC	:1.0ΩMax		HK-502BC
Z	:		
IDC	:0.38AMax	1KHz/0.25V	102LCZ&712

5. CIRCUIT :

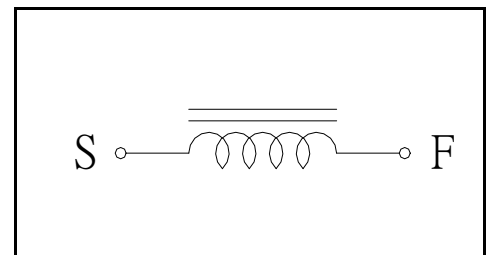

MADE BY		CHICKED BY		APPROVED BY	
---------	--	------------	--	-------------	--

SPECIFICATION FOR APPROVAL

SUSTOMER		CUS.P/N		PAGE NO	3 of 3
SXN P/N	PK0810-561KB	DATE	2017/8/8	REV.	1.0

TEST DATA

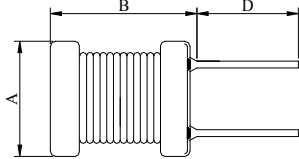
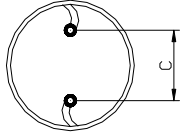
<p>TEST INSTRUMENT : <input checked="" type="checkbox"/> 1062 LCZ <input type="checkbox"/></p> <p><input checked="" type="checkbox"/> HK-502BC <input checked="" type="checkbox"/> 卡尺</p> <p>TEST TEMPERATURE 25 °C</p> <p>TEST HUMIDITY : 60 °C</p>	 
--	--

SPEC	ELECTRICAL CHARACTERISTIC						DIMENSION (UNIT:mm)					
	L	IDC	RDC				A	B	C	D		
	560UH	0.38A	1.0Ω				9.5Max	12.3Max	4.0Ref	15.0Ref		
	±10%	≥L(0A)*75%	Max									
1	553.00	80.0%	0.96				8.95	11.89	4.00	15.00		
2	554.00	81.0%	0.97				8.99	11.95	4.00	15.00		
3	552.00	79.0%	0.96				9.01	11.85	4.00	15.00		
4	550.00	78.0%	0.97				9.03	11.84	4.00	15.00		
5	553.00	79.0%	0.98				9.02	11.78	4.00	15.00		
6												
7												
8												
9												
10												
MAX	554.00	79.0%	0.98				9.03	11.95	4.00	15.00		
MIN	550.00	78.0%	0.96				8.95	11.78	4.00	15.00		
R	4.00	1.0%	0.02				0.08	0.17	0.00	0.00		
X̄	552.4	92.4%	0.968				9	11.862	4	15.000		
判定	OK	OK	OK				OK	OK	OK	OK		

MADE BY		CHICKED BY		APPROVED BY	
---------	--	------------	--	-------------	--

1
2
3
4
5
6
7
8
9
10
11
12
13
14
15
16
17
18
19
20
21
22
23
24
25
26
27
28
29
30
31
32
33
34
35
36
37
38
39
40
41
42
43
44
45
46
47
48
49
50
51
52
53
54
55
56
57
58
59
60
61
62
63
64
65
66
67
68
69
70
71
72
73
74
75
76
77
78
79
80
81
82
83
84
85
86
87
88
89
90
91
92
93
94
95
96
97
98
99
100

1
2
3
4
5
6
7
8
9
10
11
12
13
14
15
16
17
18
19
20
21
22
23
24
25
26
27
28
29
30
31
32
33
34
35
36
37
38
39
40
41
42
43
44
45
46
47
48
49
50
51
52
53
54
55
56
57
58
59
60
61
62
63
64
65
66
67
68
69
70
71
72
73
74
75
76
77
78
79
80
81
82
83
84
85
86
87
88
89
90
91
92
93
94
95
96
97
98
99
100